



# Dragflow Electric Pump

## EL1204



**Electric Motor**  
Insulation class H



**Cable**  
1 x H07RN-F 4G50 length 20m



**Operating Conditions**  
Max liquid temperature 35°C  
Min Submersion depth 1510 mm

### Model EL 1204

Brake Power	90 kW	120 hp
Electric Power	96 kW	128 hp
Frequency [Hz]	50	60
Efficiency	53%	54%
Number of Poles	4	4
RPM	1480	1776
Voltage [V]	400	460
Rated Current [A]	158	141
Solid Handling	60 mm	2.4"
Discharge [DN-PN]	150	10

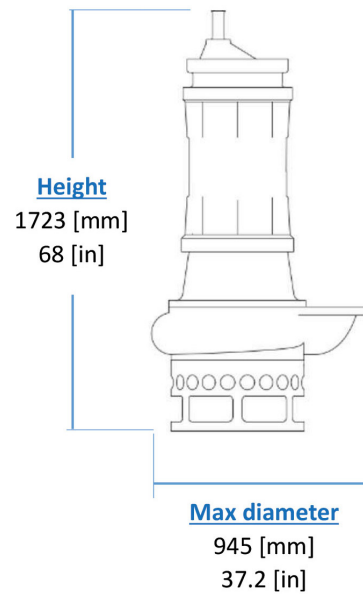

**KG**  
**Weight**  
(without cable)  
1250 [kg]  
2755 [lb]

### Materials

Part	Standard
Casing	Cast Iron EN-GJL800
Body	Cast Iron EN-GJL250
Wear Parts	High chrome EN-GJN-HV600 (CH6)
Minimum hardness [HB]	550
Main shaft	High tensile 39NiCrMo3
PH Range	5-10

### Seals and lubricants

Version	EL1204	MG	MS
Motor Side	LIPS	MECHANICAL	MECHANICAL
Impeller Side	LIPS	LIPS	MECHANICAL
Oil type	EP320	ISO32	ISO32

