



Dragflow Electric Pump

EL1204UHH



Electric Motor
Insulation class H



Cable
2 x H07RN-F 4G35 length 20m



Operating Conditions

Max liquid temperature 35°C
Min Submersion depth 1700 mm

Model EL 1204UHH

Brake Power	120 kW	160 hp
Electric Power	128 kW	171 hp
Frequency [Hz]	50	60
Efficiency	43%	42%
Number of Poles	4	4
RPM	1450	1740
Voltage [V]	400	460
Rated Current [A]	206	180
Solid Handling	20 mm	0.8"
Discharge [DN-PN]	100	10

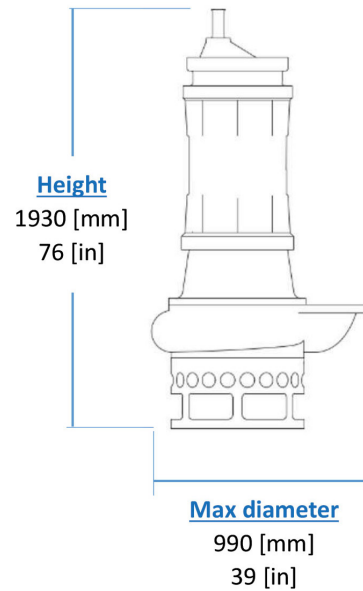

KG
Weight
(without cable)
1850 [kg]
4080 [lb]

Materials

Part	Standard
Casing	Cast Iron EN-GJL800
Body	Cast Iron EN-GJL250
Wear Parts	High chrome EN-GJN-HV600 (CH6)
Minimum hardness [HB]	550
Main shaft	High tensile 39NiCrMo3
PH Range	5-10

Seals and lubricants

Version	-	MG	MS
Motor Side	-	MECHANICAL	MECHANICAL
Impeller Side	-	LIPS	MECHANICAL
Oil type	-	ISO32	ISO32

