



Dragflow Electric Pump

EL150



Electric Motor
Insulation class H



Cable
1 x H07RN-F 4G95 length 20m



Operating Conditions

Max liquid temperature 35°C
Min Submersion depth 2280 mm

Model EL 150

Brake Power	110 kW	147 hp
Electric Power	120 kW	161 hp
Frequency [Hz]	50	60
Efficiency	64%	63%
Number of Poles	10	10
RPM	585	700
Voltage [V]	400	460
Rated Current [A]	217	190
Solid Handling	120 mm	4.7"
Discharge [DN-PN]	250	PN10

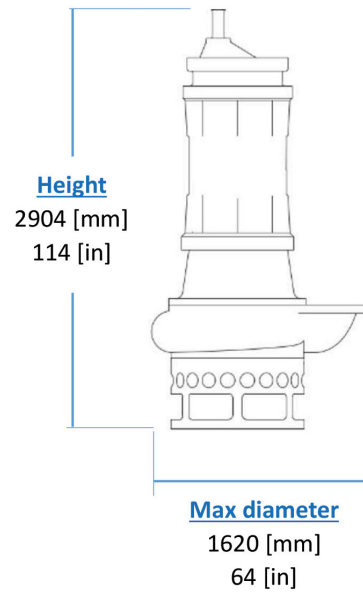

KG
Weight
(without cable)
4500 [kg]
9920 [lb]

Materials

Part	Standard
Casing	Cast Iron EN-GJS500
Body	Cast Iron EN-GJS500
Wear Parts	High chrome EN-GJN-HV600 (CH6)
Minimum hardness [HB]	550
Main shaft	High tensile 39NiCrMo3
PH Range	5-10

Seals and lubricants

Version	STANDARD	MS
Motor Side	LIPS	MECHANICAL
Impeller Side	LIPS	MECHANICAL
Oil type	EP320	ISO32

