



Dragflow Electric Pump

EL1506



Electric Motor
Insulation class H



Cable
1 x H07RN-F 4G95 length 20m



Operating Conditions
Max liquid temperature 35°C
Min Submersion depth 1820 mm

Model EL 1506

Brake Power	110 kW	147 hp
Electric Power	120 kW	161 hp
Frequency [Hz]	50	-
Efficiency	62%	-
Number of Poles	6	-
RPM	980	-
Voltage [V]	400	-
Rated Current [A]	210	-
Solid Handling	60 mm	2.4"
Discharge [DN-PN]	200	PN10

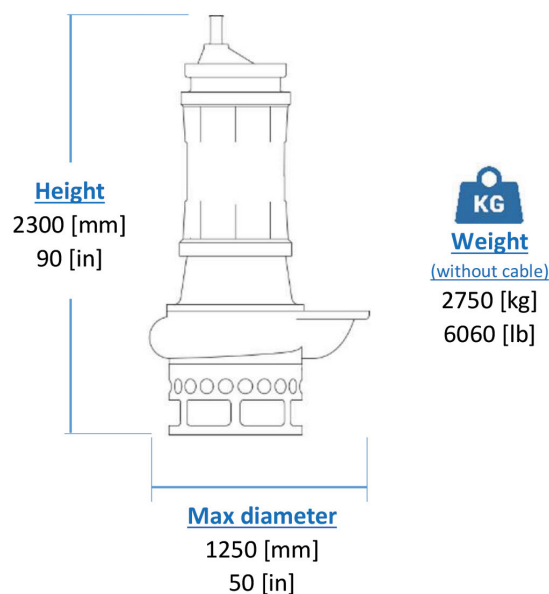

Materials

Part	Standard
Casing	Cast Iron EN-GJL500
Body	Cast Iron EN-GJL250
Wear Parts	High chrome EN-GJN-HV600 (CH6)
Minimum hardness [HB]	550
Main shaft	High tensile 39NiCrMo3
PH Range	5-10

Seals and lubricants

Version	-	-	MS
Motor Side	-	-	MECHANICAL
Impeller Side	-	-	MECHANICAL
Oil type	-	-	ISO32

