



Dragflow Electric Pump

EL180



Electric Motor
Insulation class H



Cable
1 x H07RN-F 4G95 length 20m



Operating Conditions

Max liquid temperature 35°C
Min Submersion depth 1820 mm

Model EL 180

Brake Power	130 kW	180 hp
Electric Power	138 kW	160 hp
Frequency [Hz]	50	60
Efficiency	56%	55%
Number of Poles	6	6
RPM	980	1176
Voltage [V]	400	460
Rated Current [A]	220	190
Solid Handling	60 mm	2.4"
Discharge [DN-PN]	200	10

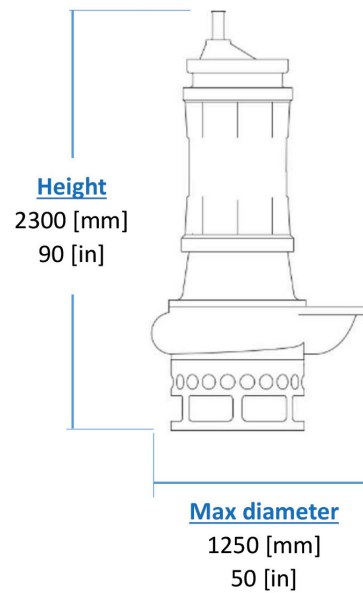

KG
Weight
(without cable)
2750 [kg]
6060 [lb]

Materials

Part	Standard
Casing	Cast Iron EN-GJS500
Body	Cast Iron EN-GJS250
Wear Parts	High chrome EN-GJN-HV600 (CH6)
Minimum hardness [HB]	550
Main shaft	High tensile 39NiCrMo3
PH Range	5-10

Seals and lubricants

Version	-	-	MS
Motor Side	-	-	MECHANICAL
Impeller Side	-	-	MECHANICAL
Oil type	-	-	ISO32

