



Dragflow Electric Pump

EL60



Electric Motor
Insulation class H



Cable
1 x H07RN-F 4G35 length 20m



Operating Conditions

Max liquid temperature 35°C
Min Submersion depth 1510 mm

Model EL 60

Brake Power	45 kW	60 hp
Electric Power	49 kW	66 hp
Frequency [Hz]	50	60
Efficiency	52%	60%
Number of Poles	6	6
RPM	980	1176
Voltage [V]	400	460
Rated Current [A]	88	79
Solid Handling	60 mm	2.4"
Discharge [DN-PN]	150	10

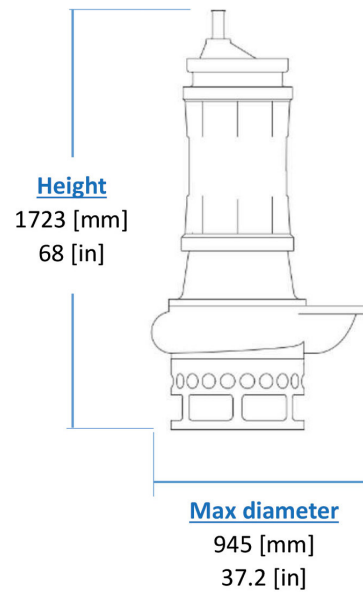

KG
Weight
(without cable)
1060 [kg]
2337 [lb]

Materials

Part	Standard
Casing	Cast Iron EN-GJS500
Body	Cast Iron EN-GJS250
Wear Parts	High chrome EN-GJN-HV600 (CH6)
Minimum hardness [HB]	550
Main shaft	High tensile 39NiCrMo3
PH Range	5-10

Seals and lubricants

Version	EL60	MG	MS
Motor Side	LIPS	MECHANICAL	MECHANICAL
Impeller Side	LIPS	LIPS	MECHANICAL
Oil type	EP320	ISO32	ISO32

