



Dragflow Hydraulic Pump

HY18

Parts
Service line Ports: SAE J518 3/4in
Case drain Port: DIN3852 M18x1,5

Operating Conditions
Max liquid temperature 40°C
Min Submersion depth 350mm

Model HY18

Brake Power [kW HP]	13 kW	17 HP
Efficiency [%]	22	
RPM Max	2000	
Motor Displacement [cc]	23	
Oil flow rate max [l/min]	46	
Nominal pressure [bar]	200	
Max pressure [bar]	350	
Solid Handling	20 mm	0.8"
Discharge (Hose adaptor)	80 mm	3"

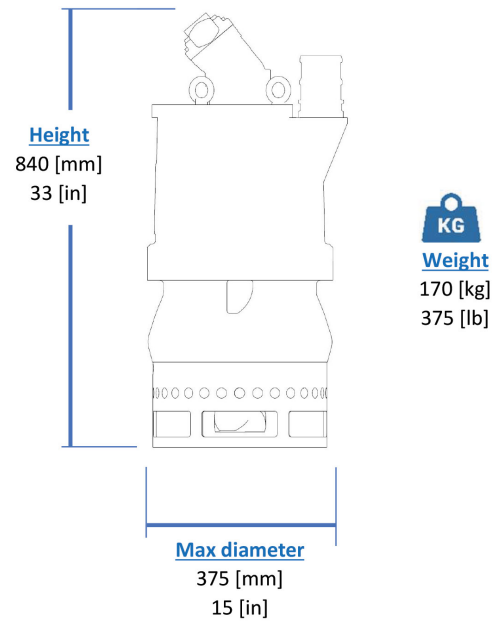

Materials

Part	Standard
Casing	Cast Iron EN-GJS500
Body	Cast Iron EN-GJS500
Wear Parts	High chrome EN-GJN-HV600 (CH6)
Minimum hardness [HB]	550
Main shaft	High tensile 39NiCrMo3
PH Range	5-10

Seals and lubricants

Version	-	-	MS
Motor Side	-	-	MECHANICAL
Impeller Side	-	-	MECHANICAL
Oil type	-	-	ISO32

