



Dragflow Hydraulic Pump

HY300

Parts
Service line Ports: SAE J518 1 1/4in
Case drain Port: DIN3852 M33x2

Operating Conditions
Max liquid temperature 40°C
Min Submersion depth 1400mm

Model HY300

Brake Power [kW HP]	220 kW	300 HP
Efficiency [%]	50	
RPM Max	750	
Motor Displacement [cc]	500	
Oil flow rate max [l/min]	380	
Nominal pressure [bar]	300	
Max pressure [bar]	350	
Solid Handling	120 mm	4.7"
Discharge [DN PN]	250	PN10

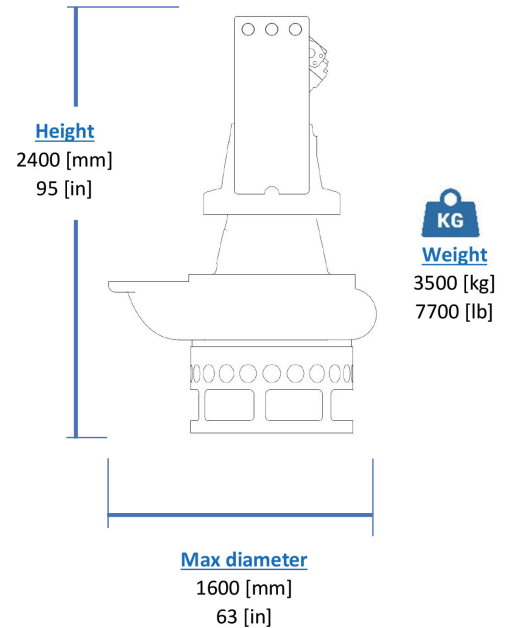

Materials

Part	Standard
Casing	Cast Iron EN-GJS500
Body	Cast Iron EN-GJS500
Wear Parts	High chrome EN-GJN-HV600 (CH6)
Minimum hardness [HB]	550
Main shaft	High tensile 39NiCrMo3
PH Range	5-10

Seals and lubricants

Version	HY300	MG
Motor Side	LIPS	MECHANICAL
Impeller Side	LIPS	LIPS
Oil type	EP320	ISO32

