



# Dragflow Hydraulic Pump

## HY400

**Parts**  
Service line Ports: SAE J518 1 1/4in  
Case drain Port: DIN3852 M33x2

**Operating Conditions**  
Max liquid temperature 40°C  
Min Submersion depth 1400mm

### Model HY400

Brake Power [kW   HP]	300 kW	400 HP
Efficiency [%]	50	
RPM Max	850	
Motor Displacement [cc]	710	
Oil flow rate max [l/min]	605	
Nominal pressure [bar]	300	
Max pressure [bar]	350	
Solid Handling	120 mm	4.7"
Discharge [DN   PN]	300	PN10

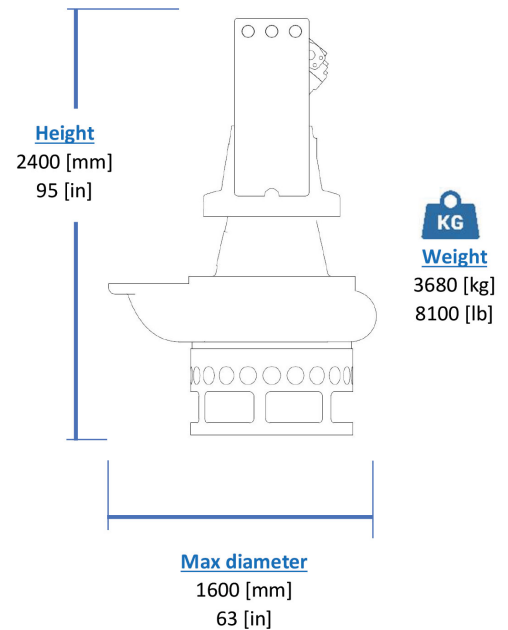

### Materials

Part	Standard
Casing	Cast Iron EN-GJS500
Body	Cast Iron EN-GJS500
Wear Parts	High chrome EN-GJN-HV600 (CH6)
Minimum hardness [HB]	550
Main shaft	High tensile 39NiCrMo3
PH Range	5-10

### Seals and lubricants

Version	HY400	MG
Motor Side	LIPS	MECHANICAL
Impeller Side	LIPS	LIPS
Oil type	EP320	ISO32

