



# Dragflow Hydraulic Pump

## HY85-180

**Parts**  
Service line Ports: SAE J518 1 1/4in  
Case drain Port: DIN3852 M22x1,5

**Operating Conditions**  
Max liquid temperature 40°C  
Min Submersion depth 440mm

### Model HY85-180

Brake Power [kW   HP]	130 kW	170 HP
Efficiency [%]	51	
RPM Max	1450	
Motor Displacement [cc]	160	
Oil flow rate max [l/min]	260	
Nominal pressure [bar]	300	
Max pressure [bar]	350	
Solid Handling	60 mm	2.4"
Discharge [DN   PN]	200	PN10

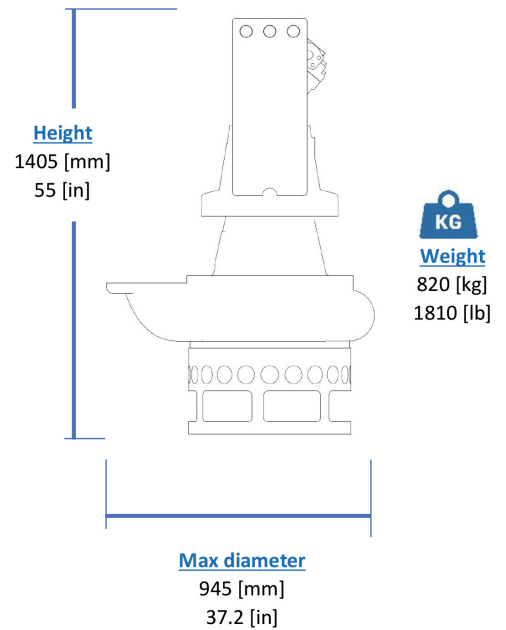

### Materials

Part	Standard
Casing	Cast Iron EN-GJS500
Body	Cast Iron EN-GJL250
Wear Parts	High chrome EN-GJN-HV600 (CH6)
Minimum hardness [HB]	550
Main shaft	High tensile 39NiCrMo3
PH Range	5-10

### Seals and lubricants

Version	HY85-180	MG	MS
Motor Side	LIPS	MECHANICAL	MECHANICAL
Impeller Side	LIPS	LIPS	MECHANICAL
Oil type	EP320	ISO32	ISO32

